

T 227 om-94

TENTATIVE STANDARD – 1943
OFFICIAL STANDARD – 1946
REVISED – 1958
OFFICIAL TEST METHOD – 1985
REVISED – 1992
REVISED – 1994
© 1984 TAPPI

The information and data contained in this document were prepared by a technical committee of the Association. The committee and the Association assume no liability or responsibility in connection with the use of such information or data, including but not limited to any liability or responsibility under patent, copyright, or trade secret laws. The user is responsible for determining that this document is the most recent edition published.

Freeness of pulp (Canadian standard method)

1. Scope

The freeness of pulp is designed to give a measure of the rate at which a dilute suspension of pulp (3 g of pulp in 1 L of water) may be drained. The freeness, or drainage rate (see TAPPI T 221 "Drainage Time of Pulp"), has been shown to be related to the surface conditions and swelling of the fibers. Besides these factors, the result is dependent also on conditions under which the test is carried out, such as stock preparation, temperature, and water quality.

2. Significance

The procedure was originally designed to yield a test value suitable primarily for the control of manufacture of groundwood. It is also widely used to follow the changes in drainage rate of various chemical pulps during beating and refining. Treatments which produce a large proportion of fines may sometimes cause an anomalous rise of freeness (false freeness) usually at values below 100 mL. Freeness values do not necessarily correlate with the drainage behavior of pulp material on a commercial paper machine.

3. Apparatus

3.1 *The freeness tester*¹ consists of a drainage chamber and a rate measuring funnel, mounted on a suitable support (see Fig. 1). The apparatus is manufactured to drawings and specifications and each instrument is inspected and calibrated before delivery. Some instruments may have a coating of marine varnish on the surface (see caution note in section 5.1.2).

3.1.1 The drainage chamber is a brass cylinder, the bottom of which contains a perforated brass screen plate and is closed with an air-tight lid, hinged on one side of the cylinder and latched at the other. The lid should be fitted so that not more than 5 mL of water will flow when the bottom cover is opened at the start of a test.

3.1.2 The upper end of the cylinder is closed by a similar lid, attached to the shelf bracket in which the cylinder is held when in use. The hinge and latching mechanisms are designed to provide an air-tight closure by means of a rubber gasket on the inside of the lid. An air-cock is inserted in the center of the upper lid to admit air to the cylinder at the start of a test.

¹Names of suppliers of testing equipment and materials for this method may be found on the Test Equipment Suppliers list in the bound set of TAPPI Test Methods, or may be available from the TAPPI Technical Operations Department.

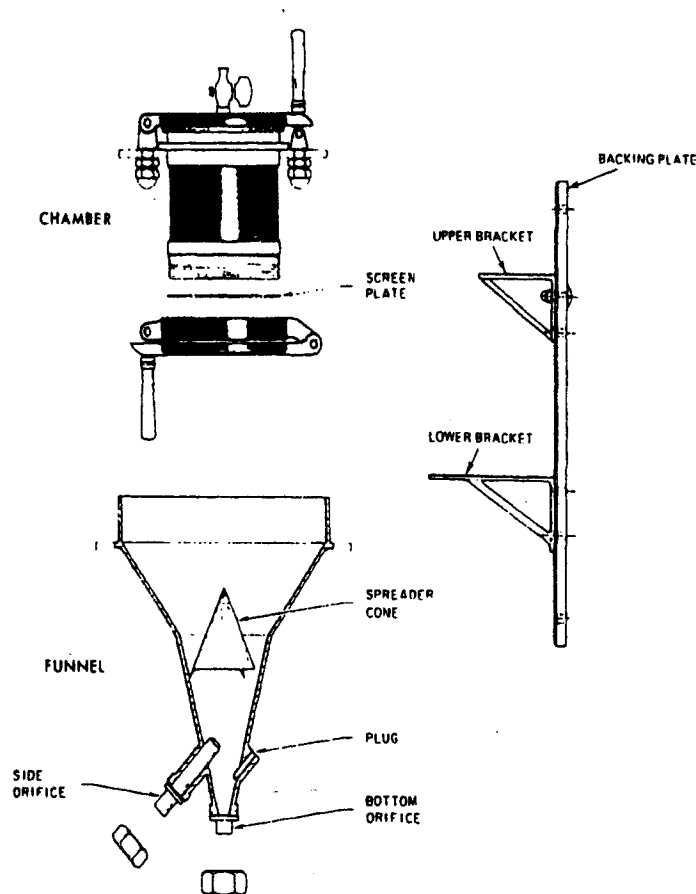

Fig. 1. Freeness tester (new model).

3.1.3 The cylinder is 101.6 ± 0.5 mm (4 in.) inside diameter by 127.0 ± 1.0 mm (5 in.) inside height. The height gives a capacity of slightly over 1000 mL above the screen plate. The air-cock bore is 4.8 mm. This dimension is not critical but should not be substantially reduced.

3.1.4 The screen plate is $112.0 + 0.5$ mm - 0.0 mm in diameter, $0.51 \text{ mm} \pm 0.05$ mm (0.020 in.) thick and has perforations of 0.51 mm diameter spaced 625 per 1 in.² (about 97 per cm²) of surface. The plate is mounted so that the burr of the punched perforations is downward.

NOTE 1: Since it has not been possible to duplicate these plates by reference to the dimension of the holes, all plates are standardized by comparison against master plates.

3.1.5 The rate measuring funnel is 203 mm (8 in.) open top diameter by overall length 278 mm (10 15/16 in.). The main cone has a $29^\circ \pm 5'$ slope on the inside which flares out into a top cylindrical portion. The bottom (apex) terminates in a carefully machined orifice piece attached to the bottom of the funnel. The funnel is also provided with a side discharge orifice.

3.1.6 The side discharge orifice consists of a hollow tube, 12.7 mm (0.50 in.) inside diameter, which penetrates the well of the funnel. This tube is inserted so that the distance between the overflow lip of the tube inside the funnel and the bottom of the funnel section is 50.8 ± 0.7 mm.

NOTE 2: The measurement of the side orifice is extremely critical and set during the calibration before being sent to the purchaser. It **MUST NOT** be changed. If disturbed, it should be returned to the supplier for recalibration.

3.1.7 The volume in the bottom section of the funnel, between the bottom of the funnel and the overflow lip of the side orifice is adjusted to 23.5 ± 0.2 mL. This volume is adjusted during calibration and **must not** be changed.

NOTE 3: In 1967, the manufacturer not only changed the angle of the side orifice but also changed the angle of opening from angular to square cut. If the serial number on the CSF tester is not preceded by the letter "M," the tester is a pre-1967 model (see Appendix). PAPRICAN reports that this change does not affect the test result.

NOTE 4: The assembled tester is checked and certified that it matches the performance of a master standard tester, and the bottom orifice, side orifice and funnel volume are adjusted to meet specifications. **Any change in the critical adjustments will affect calibration and render the certification invalid.** At a minimum, freeness testers in frequent use should be recalibrated every five years or sooner for instruments used with pulps containing high resin contents or residual bleaching chemicals.

3.1.8 A detachable spreader cone is supported on three legs inside the funnel to prevent splash from directly entering the side orifice.

3.1.9 The cylinder and the drainage cone are each supported by flanges in the openings of two machined brackets supported by a backing plate. Mount the instrument so as to minimize vibration. Level by means of a machinist's level placed on the open top of the rate measuring funnel, in position in the lower bracket. Rotation of the level on the funnel will show when the instrument is mounted in a true level position. When the funnel is mounted in this fashion, the remaining components will be properly aligned, and the instrument is ready for operation.

3.2 *Graduated cylinders*, 1000 mL and one of the same or lesser capacity with 10 mL or smaller divisions, to suit the pulp being tested.

NOTE 5: Many freeness graduated cylinders are inaccurate. It is recommended that the pulp and water suspension be weighed using a tared beaker. At a minimum, check the accuracy of each freeness graduate before use.

3.3 *Standard disintegrator* (required only when pulp is not in slush form), described in Appendix A of TAPPI 205 "Forming Handsheets for Physical Tests of Pulp."

3.4 *Bucket*, of at least 10 L capacity to hold the stock.

3.5 *Dipper*, a shallow plastic cup with a thick, smooth lip is recommended.

3.6 *Büchner funnel and flask*.

3.7 *Tared filter paper*.

3.8 *Weighing bottle*, preferably a shallow type, to accommodate a folded pad of pulp from the Büchner funnel.

3.9 ASTM Type II water is preferred to run freeness tests; however, water quality of a conductance of less than 4 $\mu\text{s}/\text{cm}$ has been found acceptable. Tap water is considered unacceptable for accurate/repeatable test results (1).

4. Care of the Instrument

4.1 The instrument should be kept clean at all times, free from stock accumulations, pitch, oil or grease. After each test the chamber should be rinsed out with clean water. It is particularly necessary to see that no pulp is left on the surfaces of the chamber, funnel or in the holes of the screen plate.

NOTE 6: Continual use with a sulfite pulp or a sized paper stock will cause the surfaces inside the cone to become water repellent. Wash with a solution of a synthetic detergent and hot water to make this surface wettable, then thoroughly rinse with clean water.

4.1.1 If the instrument is to be left out of use, carefully and thoroughly wash away any pulp that might dry on it, dry with a soft lint-free cloth, close the top lid, but do not clamp it, and leave the bottom lid of the cylinder open. It is not good practice to leave water in the chamber for long periods of time. Also, it is not good practice to leave the top lid open, partially closing it by resting the lid on the top squared section of the handle. Leaving the lid closed but not clamped, which will compress the gasket, is also acceptable. Before making a test, thoroughly wet all the inside surfaces with distilled or deionized water at the temperature of the stock to be tested. If a detergent is used, rinse well with clean hot water to remove all traces of detergent...THIS IS MOST IMPORTANT.

NOTE 7: The practice of keeping an extra standard screen plate for a reference standard is strongly recommended. The screen plate in current use may then be checked at regular intervals. After use the reference plate should always be rinsed with hot water, then rinsed in methanol and dried with a lint-free cloth. With careful use a screen plate has a long life, but under usual mill conditions, it may become dirty with resin accumulation. This resin may be removed with an organic solvent or by gently brushing a mild detergent free from carboxymethyl-cellulose and phosphates, followed by a thorough washing with hot water. **Under no circumstances may acid be used to clean the screen plate. Bent or damaged screen plates must not be used.**

4.1.2 When replacing the screen plate, care must be taken when tightening the collar to avoid squeezing the chamber out of round. If necessary, a strap wrench, **not a vise**, to grip it and a suitable mount to hold the collar and screen plate in place are recommended.

5. Calibration

5.1 Actual calibration can only be done against a master instrument maintained by a provider of calibration standards². However, a quick on-site check can be carried out to assess the calibration of the instrument.

5.1.1 Run the water check. The certificate of inspection issued for each tester gives a value (using distilled or deionized water at 20°C) for the side orifice discharge which may be used as a field check on the bottom orifice. The test is described on the certificate. Instruments manufactured or calibrated by a provider of calibration standards are issued with specific water check valves. In general, one provider of calibration standards reports that most instruments have water test valves in the range of 880 to 890 mL distilled or deionized water at 20°C. Due to the inaccuracies of some graduated freeness cylinders, the graduations should be verified by weight (see note 5) or the water check should be performed by gravimetric techniques using a tared beaker of 1000-mL capacity.

5.1.2 When the flow is less than specified, the instrument should be cleaned with an organic solvent or detergent, followed by thorough rinsing with hot water. More drastic cleaning may destroy the calibration of the bottom orifice. If the flow is greater than the specified value, the bottom orifice must be replaced. **Caution:** Some freeness instruments are manufactured and calibrated with an inside coating of marine varnish. "Aggressive" cleaning may remove this coating. As a result, the instrument will yield different results with/without the varnish coating.

5.1.3 Standard reference pulps are available² and should be used to also check the calibration. Calibration checks with reference pulps should be done by weight only (no graduate). The directions for the initial ("0" point CSF) pulp dispersion and \pm mL specifications can be followed to check the freeness tester calibration (along with the water check).

NOTE 8: Instruments are calibrated as a unit, therefore, DO NOT interchange cylinders and/or funnels between CSF testers.

6. Sampling

6.1 When dealing with a mill consignment, take sample of pulp, about 25.8 cm² (4 in.²) in area, from the interior of every bale included in the official test for moisture. Portions of specimens taken for the moisture test, but not dried, may be used. The weight of the composite sample should be at least 50 g, preferably 100 g or more, of dry fiber for duplicate tests.

6.1.1 For slush pulps, take a representative sample equivalent to at least 10 g of dry fiber.

6.2 *Test specimen.* Unless the pulp is in slush form, the specimen should be prepared for disintegration in water as follows: Weigh to the nearest 0.5 g a representative specimen by tearing equal portions from all the sample collected, equivalent to 24 g of moisture free fiber. DO NOT cut the pulp or use cut edges. If the sample is dry, wet it thoroughly with cold water, tear, not cut, into pieces about 2.5 cm square (1 in. square) and soak in distilled or deionized water in a bucket for at least 4 h, or in the case of a dried sample of mechanical pulp which is to be furnished in the moist form, allow it to soak for 24 h.

NOTE 9: As far as it is known, soaking pulp for longer than 4 h does not appreciably affect the results.

7. Disintegration

7.1 Make the mixture up to 2000 mL (1.2% consistency) with water at $20 \pm 2^\circ\text{C}$ (see 6.2 test specimen). The consistency at which the pulp is disintegrated, as well as the disintegration time, is critical for reproducibility. Failure to disintegrate a sample at the correct consistency (1.20%), as well as disintegrating a sample for too long a time, will change values significantly of any pulp, especially bleached pulp (hardwoods are most sensitive). Any pulp should be disintegrated just until no fiber bundles remain. It is recommended that samples be disintegrated one minute and then visually examined by diluting a sample portion of the pulp sample to see that no fiber bundles are present, repeating the process until only individual fibers remain.

NOTE 10: The freeness of pulp is known to be affected by dissolved solids and the pH of water used in the determination. Distilled or deionized water **MUST** be used for dilution of the stock. Disintegration may reduce the freeness of the pulp; therefore, it is important that the disintegration time is part of the report.

7.2 Take the temperature of the stock and the water to be used for diluting. Dilute the defibered pulp to $0.3 \pm 0.02\%$ (moisture free) consistency after adjusting the temperature of the stock in the bucket to $20 \pm 2^\circ\text{C}$ (see Section 9 Consistency).

NOTE 11: It is necessary that the water holding the pulp suspension be sufficiently free from dissolved air so that sample bubbles are not liberated from the water on standing. Bubbles adhere to the fibers and cause erroneous results that may either be positive or negative in the freeness results. Water taken from high pressure mains may require to be left standing for several hours, or else subjected to a vacuum before use.

NOTE 12: For groundwood it is not necessary that either the exact consistency or temperature be used, as tables are provided which permit correcting the result to that for standard conditions. Stock consistency should be between 0.27 to 0.33% and stock temperature between 17 to 23°C . Note that corrections beyond the $\pm 0.3\%$ consistency and temperature beyond $\pm 3^\circ\text{C}$ of the standard temperature do not fulfill the conditions of this method and may result in questionable results. **The correction tables presented in this method were developed from groundwood freeness evaluation studies; the accuracy of the correction tables for chemical pulp freeness has not been determined.** For accuracy, in the case of pulps other than groundwood, it is advisable to adjust the slush pulp to the standard conditions of consistency and temperature.

8. Procedure

8.1 Thoroughly clean and wet the freeness tester with distilled or deionized water at the temperature of the stock to be tested.

8.1.1 Place the drainage chamber on the upper supporting bracket with its lower lid closed and the upper lid and air-cock open.

8.1.2 Place the graduated cylinder in position to receive the discharge from the side orifice, and a container to collect the discharge from the bottom orifice.

NOTE 13: In the freeness test collect the discharge from the side and bottom orifices along with the dewatered sample from the chamber for use in determining the consistency (see 9.1).

8.2 Thoroughly stir the stock in the bucket to ensure a homogeneous mix and accurately measure 1000 mL into a clean 1-L cylinder. Take its temperature to the nearest 0.5°C .

8.2.1 Mix the sample in the graduated cylinder by closing the top of the cylinder with the hand and gently invert the cylinder 180° three times.

8.2.2 Pour the stock *gently* but as *rapidly* as possible into the chamber. It is imperative that at the end of the pouring, the stock be almost motionless in the chamber. *This step is critical.*

8.2.3 Close the top of the lid and the air-cock. Open the bottom lid. After 5 s from the time the addition of the stock is completed, fully open the air-cock in a single motion.

8.2.4 When the side discharge has ceased, record the volume discharged from the side orifice in milliliters to the maximum accuracy possible for the graduate used (see 10.1).

9. Consistency

9.1 To determine consistency, combine the pulp from the chamber along with the discharges from the side and bottom orifices and drain the slurry from the chamber onto a tared filter paper in a Büchner funnel or in a low deckle sheet machine.

NOTE 14: Make sure no appreciable amount of fibers is left on the surface of the chamber or on the screen plate.

9.1.1 Oven dry and determine the weight of the pad. Subtract the weight of the tared filter paper to obtain the weight of the pulp. Where necessary, correct this volume to the standard consistency of 0.3% and temperature of 20°C using the correction Tables 1 and 2 in this method.

TABLE I. FREENESS CORRECTIONS TO 20°C *

Free- ness read	Temperature of stock at test, °C														Free- ness read							
	10	11	12	13	14	15	16	17	18	19	20	21	22	23		24	25	26	27	28	29	30
	Points freeness to be added										Points freeness to be subtracted											
30	11	9	8	7	6	5	4	3	2	1	0	1	2	3	4	5	6	7	8	9	11	30
40	12	10	9	8	7	6	5	3	2	1	0	1	2	3	5	6	7	8	9	10	12	40
50	14	12	11	10	8	7	6	4	3	1	0	1	3	4	6	7	8	10	11	12	14	50
60	15	14	12	11	9	8	6	4	3	1	0	1	3	4	6	8	9	11	12	14	15	60
70	17	15	13	12	10	8	7	5	3	2	0	2	3	5	7	8	10	12	13	15	17	70
80	19	17	15	13	11	9	8	6	4	2	0	2	4	6	8	9	11	13	15	17	19	80
90	20	18	16	14	12	10	8	6	4	2	0	2	4	6	8	10	12	14	16	18	20	90
100	21	19	17	15	13	10	8	6	4	2	0	2	4	6	8	10	13	15	17	19	21	100
110	23	21	18	16	14	11	9	7	5	2	0	2	5	7	9	11	14	16	18	21	23	110
120	25	22	20	17	15	12	10	7	5	2	0	2	5	7	10	12	15	17	20	22	25	120
130	26	23	21	18	16	13	11	8	5	3	0	3	5	8	11	13	16	18	21	23	26	130
140	27	24	22	19	16	14	11	8	5	3	0	3	5	8	11	14	16	19	22	24	27	140
150	29	26	23	20	17	14	11	9	6	3	0	3	6	9	11	14	17	20	23	26	29	150
160	30	27	24	21	18	15	12	9	6	3	0	3	6	9	12	15	18	21	24	27	30	160
170	31	28	25	22	18	15	12	9	6	3	0	3	6	9	12	15	18	22	25	28	31	170
180	32	29	26	22	19	16	13	10	6	3	0	3	6	10	13	16	19	22	26	29	32	180
190	33	30	26	23	20	16	13	10	6	3	0	3	6	10	13	16	20	23	26	30	33	190
200	34	31	27	24	20	17	13	10	7	3	0	3	7	10	13	17	20	24	27	31	34	200
210	35	31	28	24	21	18	14	10	7	3	0	3	7	10	14	18	21	24	28	31	35	210
220	36	32	29	25	22	18	14	10	7	4	0	4	7	10	14	18	22	25	29	32	36	220
230	37	33	30	26	22	19	15	11	7	4	0	4	7	11	15	19	22	26	30	33	37	230
240	38	34	31	27	23	19	15	11	8	4	0	4	8	11	15	19	23	27	31	34	38	240
250	39	35	31	27	23	20	16	12	8	4	0	4	8	12	16	20	23	27	31	35	39	250
260	40	36	32	28	24	20	16	12	8	4	0	4	8	12	16	20	24	28	32	36	40	260
270	41	37	33	29	24	20	16	12	8	4	0	4	8	12	16	20	24	29	33	37	41	270
280	42	38	34	29	25	21	17	13	8	4	0	4	8	13	17	21	25	29	34	38	42	280
290	42	38	34	29	25	21	17	13	8	4	0	4	8	13	17	21	25	29	34	38	42	290
300	43	39	34	30	25	21	17	13	8	4	0	4	8	13	17	21	25	30	34	39	43	300
310	43	39	34	30	25	21	17	13	8	4	0	4	8	13	17	21	25	30	34	39	43	310
320	43	39	34	30	25	21	17	13	8	4	0	4	8	13	17	21	25	30	34	39	43	320
330	44	40	35	31	26	22	18	13	9	4	0	4	9	13	18	22	26	31	35	40	44	330
340	44	40	35	31	26	22	18	13	9	4	0	4	9	13	18	22	26	31	35	40	44	340
350	44	40	35	31	26	22	18	13	9	4	0	4	9	13	18	22	26	31	35	40	44	350
360	44	40	35	31	26	22	18	13	9	4	0	4	9	13	18	22	26	31	35	40	44	360
370	45	41	36	31	26	22	18	13	9	4	0	4	9	13	18	22	26	31	36	41	45	370
380	45	41	36	31	27	22	18	13	9	4	0	4	9	13	18	22	27	31	36	41	45	380
390	45	41	36	31	27	23	18	14	9	4	0	4	9	14	18	23	27	31	36	41	45	390
400	46	41	37	32	28	23	18	14	9	4	0	4	9	14	18	23	28	32	37	41	46	400
420	45	41	36	31	27	23	18	14	9	4	0	4	9	14	18	23	27	31	36	41	45	420
440	45	41	36	31	27	22	18	13	9	4	0	4	9	13	18	22	27	31	36	41	45	440
460	44	40	35	31	27	22	18	13	9	4	0	4	9	13	18	22	27	31	35	40	44	460
480	43	39	34	30	25	21	17	13	8	4	0	4	8	13	17	21	25	30	34	39	43	480
500	42	38	34	29	25	21	17	13	8	4	0	4	8	13	17	21	25	29	34	38	42	500
520	42	38	33	29	24	20	16	12	8	4	0	4	8	12	16	20	24	29	33	38	42	520
540	42	37	33	28	24	20	16	12	8	4	0	4	8	12	16	20	24	28	33	37	42	540
560	41	37	32	28	24	20	16	12	8	4	0	4	8	12	16	20	24	28	32	37	41	560
580	41	36	32	28	24	20	16	12	8	4	0	4	8	12	16	20	24	28	32	36	41	580
600	40	36	32	28	24	20	16	12	8	4	0	4	8	12	16	20	24	28	32	36	40	600
620	39	35	31	27	23	19	16	12	8	4	0	4	8	12	16	19	23	27	31	35	39	620
640	37	33	29	25	21	18	14	11	7	4	0	4	7	11	14	18	21	25	29	33	37	640
660	36	32	28	25	21	17	14	10	7	3	0	3	7	10	14	17	21	25	28	32	36	660
680	35	31	27	24	20	17	13	10	6	3	0	3	6	10	13	17	20	24	27	31	35	680
700	33	30	26	23	20	16	13	9	6	3	0	3	6	9	13	16	20	23	26	30	33	700

* Prepared by the Pulp and Paper Research Institute of Canada; vertical lines indicate the usual working range.

TABLE II. FREENESS CORRECTIONS TO 0.30% CONSISTENCY*

Free- ness read	Consistency of stock at test, %																Free- ness read					
	0.20	0.21	0.22	0.23	0.24	0.25	0.26	0.27	0.28	0.29	0.30	0.31	0.32	0.33	0.34	0.35		0.36	0.37	0.38	0.39	0.40
	Points freeness to be subtracted										Points freeness to be added											
20	0	2	3	5	7	9	11	13	15	17	19	20
30	10	8	6	4	2	0	2	4	6	8	10	13	15	17	19	21	30
40	22	20	18	16	13	11	9	7	5	2	0	3	5	7	9	12	14	17	19	21	23	40
50	25	23	20	18	15	13	10	8	6	3	0	3	6	8	10	13	16	18	21	23	25	50
60	28	25	22	19	17	14	11	9	6	3	0	3	6	9	11	14	17	19	22	25	27	60
70	31	27	23	20	18	15	12	9	5	3	0	3	6	9	12	15	18	21	24	27	29	70
80	33	29	25	22	19	16	13	9	6	3	0	4	7	10	13	16	19	22	25	28	31	80
90	36	31	27	24	21	17	13	10	7	3	0	4	7	10	13	16	20	23	26	29	32	90
100	38	33	29	26	22	18	14	10	7	3	0	4	7	11	14	17	21	24	27	30	34	100
110	40	35	31	27	23	19	15	11	7	3	0	4	8	11	14	18	22	25	28	31	35	110
120	42	37	33	29	24	19	15	11	7	3	0	4	8	11	15	19	23	26	29	33	36	120
130	44	39	35	30	25	20	16	12	8	4	0	4	8	12	15	20	24	27	31	35	38	130
140	46	41	36	31	26	21	17	12	8	4	0	4	8	12	16	20	24	28	32	36	40	140
150	48	42	37	32	27	22	17	12	8	4	0	4	8	12	16	21	25	30	34	38	42	150
160	50	44	39	33	28	23	18	13	9	4	0	4	8	13	17	22	26	31	35	39	43	160
170	52	46	40	34	29	24	19	14	10	5	0	5	9	14	18	23	27	32	36	41	45	170
180	54	48	42	36	30	25	20	15	10	5	0	5	10	15	19	24	28	33	37	42	46	180
190	56	49	43	37	31	26	20	15	10	5	0	5	10	15	19	24	28	33	38	43	47	190
200	58	51	45	38	32	26	21	15	10	5	0	5	10	15	20	25	29	34	39	44	48	200
210	60	53	46	39	33	27	21	15	10	5	0	5	10	16	21	26	30	35	40	45	49	210
220	61	54	47	40	34	28	22	16	10	5	0	5	11	16	21	26	31	36	41	46	50	220
230	62	55	48	41	35	28	22	17	11	5	0	6	12	17	22	27	32	37	42	47	51	230
240	63	56	49	42	36	29	23	17	11	5	0	6	12	17	23	28	33	38	43	48	53	240
250	64	57	50	43	37	30	23	17	11	5	0	6	12	18	23	29	34	39	44	49	54	250
260	65	58	51	44	37	30	24	18	12	6	0	7	13	19	24	30	35	40	45	50	55	260
270	67	59	52	45	38	31	25	19	12	6	0	7	13	19	25	31	36	41	46	51	56	270
280	66	60	53	46	39	32	25	19	12	6	0	7	13	19	25	31	36	41	47	52	57	280
290	70	62	54	47	40	33	26	19	13	6	0	7	13	19	25	31	36	42	47	52	57	290
300	72	64	56	48	41	34	27	20	13	6	0	7	13	19	25	31	36	42	48	53	58	300
310	73	65	57	49	41	34	27	20	13	7	0	7	13	19	25	31	37	43	48	53	58	310
320	75	66	58	50	42	35	27	20	13	7	0	7	13	19	25	31	37	43	48	53	58	320
330	77	68	59	51	43	35	27	20	13	7	0	7	13	19	25	32	38	43	48	53	58	330
340	78	69	60	52	43	35	27	20	13	7	0	7	14	20	26	32	38	44	49	54	59	340
350	79	70	61	52	43	35	27	20	13	7	0	7	14	20	26	32	38	44	49	54	59	350
360	80	70	61	52	43	35	28	21	14	7	0	7	14	20	26	32	38	44	49	54	59	360
370	81	71	61	52	44	36	28	21	14	7	0	7	14	20	26	32	38	44	49	54	59	370
380	81	71	61	52	44	36	29	21	14	7	0	7	14	20	26	32	38	44	49	54	59	380
390	82	72	62	53	45	37	29	21	14	7	0	7	14	20	26	32	38	44	49	54	59	390
400	82	72	62	53	45	37	29	21	14	7	0	7	14	20	26	32	38	44	49	54	59	400
420	83	72	62	54	45	37	29	21	14	7	0	7	14	20	26	32	38	44	49	54	59	420
440	83	73	63	54	45	37	29	21	14	7	0	7	14	20	26	32	38	44	49	54	59	440
460	83	73	63	54	45	37	29	21	14	7	0	7	14	20	26	32	38	44	49	53	58	460
480	83	73	63	54	46	37	29	21	14	7	0	7	14	20	26	32	38	42	47	52	57	480
500	83	73	63	54	46	37	29	21	14	7	0	7	14	20	26	32	36	41	46	51	56	500
520	82	72	62	53	44	36	28	21	14	7	0	7	13	19	25	30	35	40	45	50	55	520
540	80	71	62	53	44	36	28	21	14	7	0	6	12	18	24	29	34	39	44	49	54	540
560	78	69	60	51	43	35	28	21	14	7	0	6	12	17	22	27	32	37	42	47	52	560
580	76	67	58	50	42	34	27	20	13	6	0	6	12	16	22	27	32	37	42	46	50	580
600	75	66	58	50	42	34	27	20	13	6	0	6	11	16	21	26	31	36	40	44	48	600
620	74	65	57	49	41	33	26	19	12	6	0	5	10	15	20	25	30	34	38	42	47	620
640	73	64	56	48	40	32	25	18	12	6	0	5	10	15	20	25	29	33	37	41	46	640
660	71	63	55	47	39	31	24	17	11	6	0	5	9	14	19	24	28	31	35	39	45	660
680	70	63	55	46	39	31	24	16	11	5	0	4	9	13	18	23	27	30	34	38	44	680
700	69	62	54	46	38	30	23	16	11	5	0	4	8	13	18	22	26	29	33	37	42	700

* Prepared by the Pulp and Paper Research Institute of Canada; vertical lines indicated the usual working range.

NOTE 15: It is immaterial which correction is applied first, the second correction being made to the volume adjusted by the first correction.

NOTE 16: Equations have been developed that fit the data in Tables 1 and 2 (2):
 Consistency correction = $(\text{Cons}-0.3)*590*(1+(((0.4-\text{Cons})/0.2)*(CSF/1000)))*(1-((CSF-390)^2/((CSF^{0.2})*87000)))$
 Temperature correction = $(20-\text{Temp})*4.6*(1-(((400-CSF)^2)/((CSF^{0.25})*61000)))$
 where
 cons = actual consistency, %
 temperature = actual temperature, °C
 CSF = measured CSF or already corrected for one term

9.1.2 Make at least two determinations on separate portions of the same specimen and make additional tests if they differ more than 2%.

10. Report

10.1 Report the individual and average freeness readings corrected to 0.3% consistency and 20°C, to the nearest 1 mL, on readings less than 100 mL, 2 mL on readings from 100 to 250 mL, and the nearest 5 mL on readings over 250 mL.

10.1.1 Unless the sample was in slush form, state the procedure and time employed for defibering the pulp.

11. Precision

11.1 The precision of the freeness test is dependent upon the level of the test and type of pulp being tested. Long fibered pulp such as softwood chemical pulp will show more variation than hardwood or groundwood pulp. Test results between 300 to 500 mL will show more variation than with tests which are either higher or lower than this.

11.1.1 *Repeatability.* Calculations based on 486 freeness tests made in one laboratory on 53 samples of pulp indicate that the repeatability as defined in TAPPI T 1206 "Precision Statement for Test Methods" will be as follows for the average of two determinations:

<i>Freeness level</i>	<i>Softwood chemical pulp</i>	<i>Hardwood chemical pulp</i>	<i>Groundwood pulp</i>
600	12 mL	6 mL	—
400	16 mL	12 mL	—
200	12 mL	7 mL	8 mL
50			5 mL

11.1.2 *Reproducibility.* Calculations based on 162 tests made in 11 laboratories of one company indicate that softwood chemical pulp beaten to a freeness of 531 mL will have a reproducibility as defined in TAPPI T 1206 of 25 mL for the average of two measurements. Data are not available for other pulps or other freeness levels.

12. Additional Information

12.1 Effective date of issue: May 17, 1994.

12.2 Any disintegration reduces the freeness of a pulp to an extent depending on the freeness of the original stock, the degree of pressing or drying of the laps, and the time kept in the pressed condition.

12.3 As stated in Note 3, there have been significant modifications in the design, care of the instrument, and procedures. Figure 2 shows a drawing of the pre-1967 CSF tester. More complete information can be found in the 1958 version of this method (TAPPI T 227 "Freeness of Pulp" om-58).

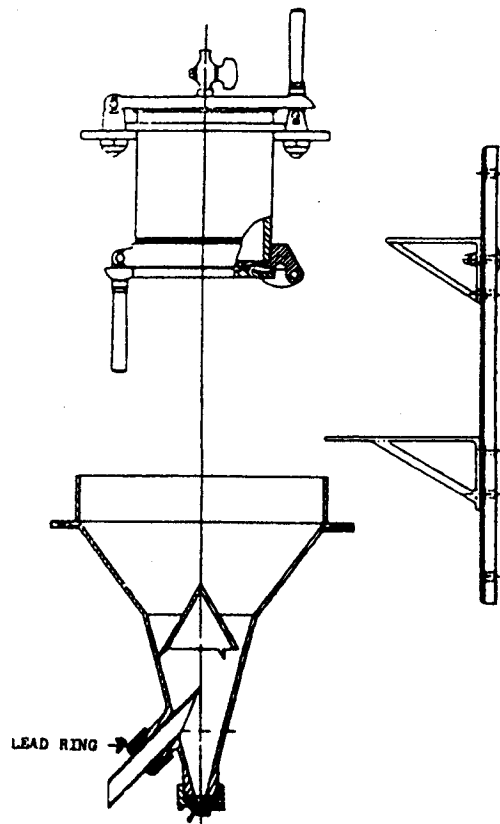

Fig. 2. Freeness tester (old model; no longer manufactured).

Literature cited

1. Adams, S. R., Simmonds, F. A., and Baird, P. K., *Tech. Assoc. Papers.* 22: 482-487 (1939).
2. Biermann, C. J. and Hull, J. H., *Tappi* 75(10): 245 (Oct. 1992).

References

Thode, E. F., and Ingmanson, W. L., *Tappi* 42(1): 74 (1959) especially p. 82.
Technical Section, Canadian Pulp & Paper Association, Official Standard Testing Method C.1, "The Determination of Freeness."

Your comments and suggestions on this procedure are earnestly requested and should be sent to the TAPPI Technical Divisions Administrator. ■